



Model 623N Deluxe

Dough Divider

Key Features:

- Manual dough divider
- Scale dough easily and accurately
 - Press dough into pan
 - Place pan into unit
 - Pull handle down to evenly distribute dough
 - Release dividing knives
- Ideal for a variety of doughs: yeast raised, cookie, and pie
- Divide ground meat or sausage for exact portion control
- Tool-free Interchangeable dividing heads for maximum processing flexibility
- 9, 18, and 36 part in round
- 9 part in square
- Choose one, two or three dividing heads
- 9 part square interchangeable with round division options
- Includes one dough pan; extra pans available
- Dividing head assemblies are dishwasher safe
- Must be bolted to bench or optional stand



Shown on optional stand

The information contained herein is correct to the best of our knowledge. The recommendations or suggestions are made without guarantee or representation as to results.

Above specifications subject to change without notice.



Manufactured in the U.S.A.



Model 623N Deluxe

Dough Divider Specifications:

Finished portion sizes:

36 part: 1—4 oz (28—113 gr)

18 part: 2—9 oz (56—255 gr)

9 part: 4—17 oz (113—582 gr)

Minimum portion size requires 2 lbs 4 oz dough ball

Maximum portion size requires 9 lb dough ball

Finish:

White powder coat finish with stainless steel pan (1)

Shipping Weight: 88 lbs (39.6 kg) - Single dividing head

104 lbs (47.2 kg) - Two dividing heads

120 lbs (54.4 kg) - Three dividing heads

Net Weight: 80 lbs. (36 kg)

Optional Stand

Net Weight: 35 lbs (16kg)

Dimensions: 18.5" x 23" x 28.5" H

Dimensions:

18.5" W x 14" D x 38.25" H

(47 cm x 35.5 cm x 97 cm)

Range of handle when pulled down: 27.25"

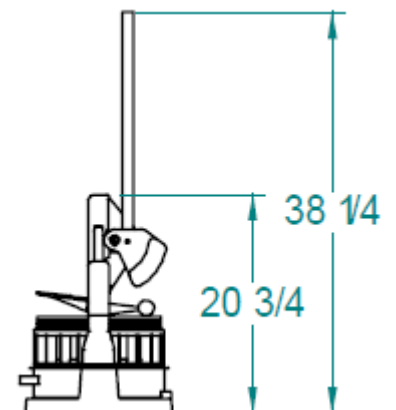
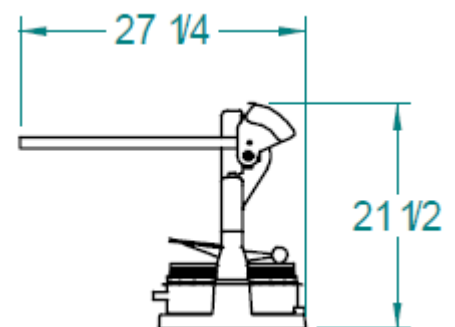
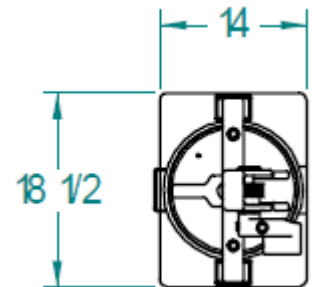

The information contained herein is correct to the best of our knowledge. The recommendations or suggestions are made without guarantee or representation as to results.

Above specifications subject to change without notice.



Manufactured in the U.S.A.