

PETITE LINE

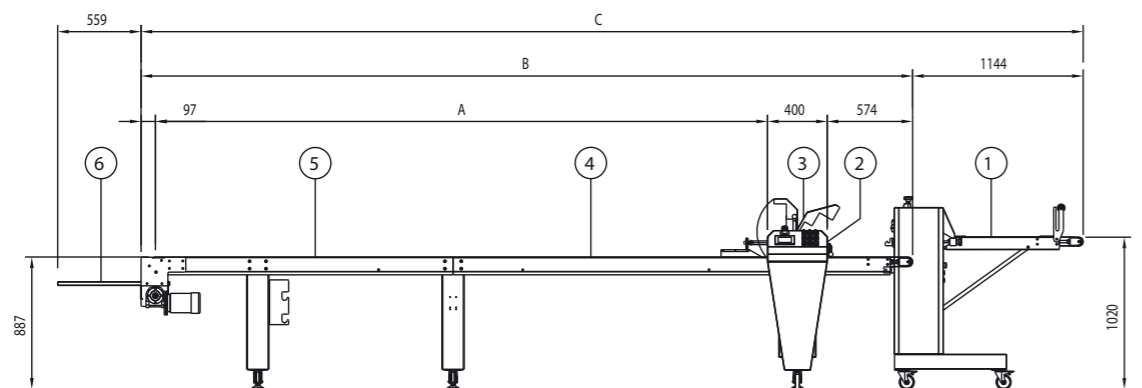

PETIT LINE				
DATI UGUALI PER TUTTI I MODELLI	MOD.: 2MT	MOD.: 3MT	MOD.: 4MT	MOD.: 5MT
	LARGH. NASTRO: 650	A: 1258	A: 2258	A: 3258
UTILE TAGLIO: 600	B: 2307	B: 3307	B: 4307	B: 5307
	C: 3728	C: 4728	C: 5728	C: 6728

- 1 - CALIBRATORE
- 2 - PANNELLO DI CONTROLLO
- 3 - DISPOSITIVO DI TAGLIO
- 4 - PIANO DI LAVORO
- 5 - MENSOLE PORTASTAMPI
- 6 - MENSOLE PORTATEGLIE

ALBA LINE

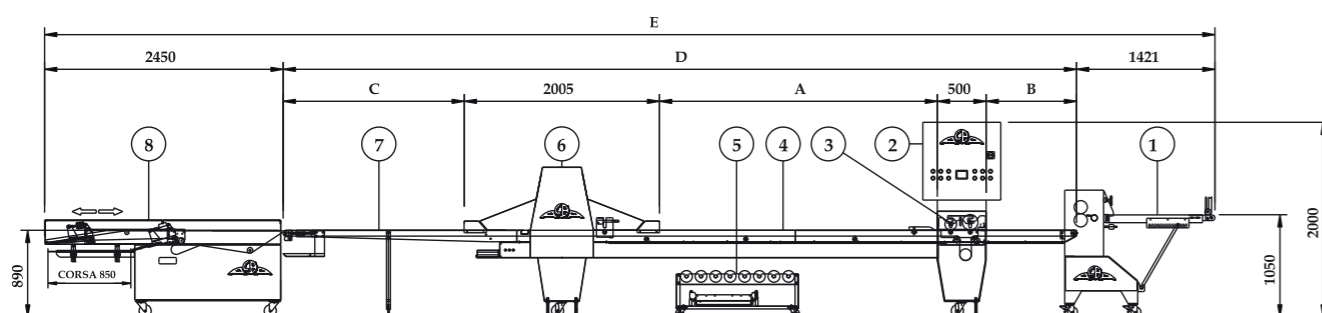

- 1 - CALIBRATORE
- 2 - PANNELLO DI CONTROLLO
- 3 - DISPOSITIVO DI TAGLIO
- 4 - PIANO DI LAVORO
- 5 - CARRELLO PORTASTAMPI
- 6 - GHIGLIOTTINA
- 7 - PIANO USCITA
- 8 - IMPADELLAMENTO AUTOMATICO

DATI UGUALI PER TUTTI I MODELLI	ALBALINE MODELLO 7.5			ALBALINE MODELLO 8.5		
	MOD.:7.5	MOD.:7.5+1	MOD7.5+1 P.E.+0.5	MOD.:8.5	MOD.:8.5+1	MOD.8.5+1 P.E.+0.5
LARGH. NASTRO: 650	A: 3055	A: 3055	A: 3055	A: 4055	A: 4055	A: 4055
UTILE TAGLIO: 600	B: 929	B: 929	B: 1429	B: 929	B: 929	B: 1429
UTILE GHIGLIOTTINA: 600 x 300	C: 960	C: 1960	C: 1960	C: 960	C: 1960	C: 1960
	D: 7449	D: 8449	D: 8949	D: 8449	D: 9449	D: 9949
	E: 11320	E: 12320	E: 12820	E: 12320	E: 13320	E: 13820

(Tutti i dati tecnici qui riportati possono essere variati dal costruttore mantenendo inalterata la funzionalità dell'impianto)

(All the above mentioned technical data can be modified accordingly without changing the functionality of the unit)



ALBA & Teknoservice s.r.l.

Via delle Industrie, 16/B 35010 VILLAFRANCA PAD. (PD) - ITALY
Tel. +39 049.9070380 - Fax +39 049.9074042
www.albaequipment.it - sales@albaequipment.it

Rivenditore

Q&BGRARICHE=1 0513



ALBA BAKERY AND PASTRY EQUIPMENT

PETITE LINE ALBA LINE

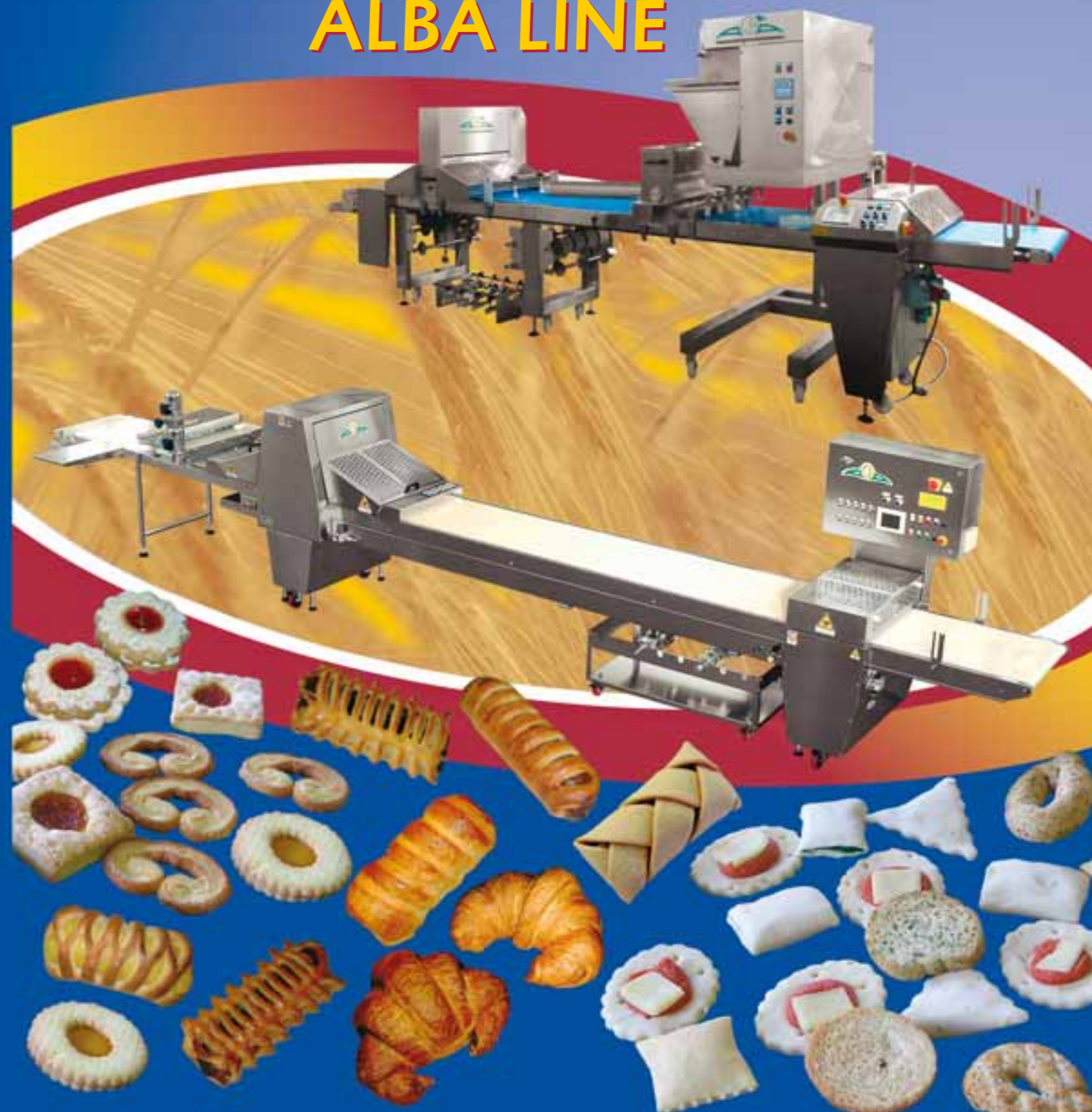



Custom made equipment for your customer made products



L'impianto su misura per i tuoi prodotti

