

DIVA HYDRAULIC PRESS



CARACTERISTICS

Aluminium tank :

No rust which means better hygiene.

Food approved plastic blocks high intensity :

Non stick surface to avoid too much flouring.

The underneath of the lid and blades made of stainless steel :

Stable and high resistance for long life.

Structure and coverings in varnished metal sheet :

Robust structure, reliable.

Structure and coverings in stainless steel metal sheet :

Robust structure, reliable and non perishable.

Lid locking pin in tempered steel in a T shape :

Ensures a nice flattening of the lid to avoid leakage of the dough with guaranteed long life.

Adjustable lid hinges:

Allows a precise adjustment of the lid on the tank without leaks of dough.

Assistance of lid opening without spring:

Assistance lid by gas jack smoothed at the end of opening to limit the shocks and without risk of breakage nor fall of the lid.

Eco-Start system:

Hydraulic pump working only in phase press or division for an energy saving and a reduction of sound transmissions.

Optimized working ergonomics:

Controls and lids at hand and working position as closely as possible to the tank for a comfort of greater work and to optimize the time of cycle.

Side handles:

Allow a movement of the machine without efforts while insuring the protection of controls.

Powerful handle of lid:

Important and ergonomic lever arm and reduction of the tightening for an effective use without efforts.

Fast descent of the tray:

Descent of the tray in 2 seconds stopwatch for a reduction of the time-outs of the baker.

Very clear interior of the machine :

Avoid at the most the zones of retentions and facilitates the maintenance of the inside of the divider.

Side doors access:

Allows to reach quickly and simply the inside of the machine while being secured by a locking key.

OPTIONS

Pressure regulator VarioPress®:

Allows to work very soft, hard or fat dough with the same machine. The settings of spreading pressure is accessible to the baker and is graduated to establish recipes.

FlourBox®:

Box with flour on ntegrated support as close as possible to the tank, removable, the flouring at hand!

Anti-Projection of flour APF®:

This system puts obstacle to the flour expelled during the compacting of the dough for a reduction of the emissions of dusts in the air.

Opening of doors without tools Easydoor®:

Closure of doors without removable key for an optimum safety : the opening causes automatically the stop of the machine.

Folding side table FlexiTable®:

This tablet positioned on the right side of the divider allows to lay dough or other plates. It can be folded with a simple click to adapt itself to your needs even in cramped spaces.

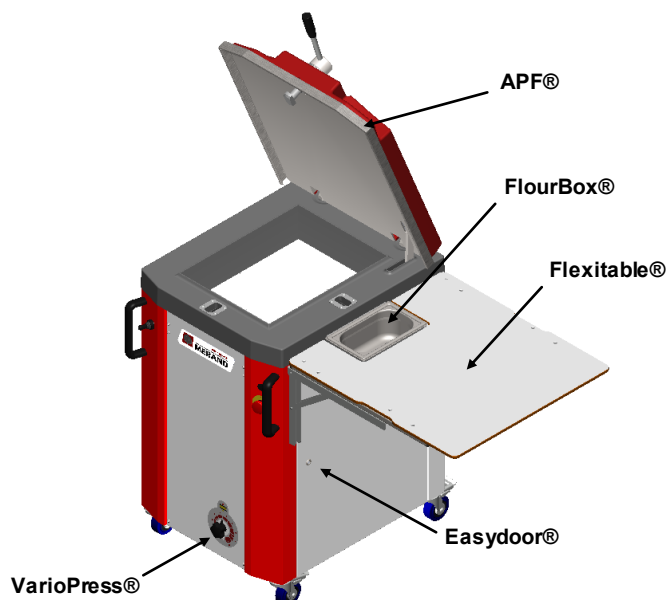

OVERALL DIMENSIONS

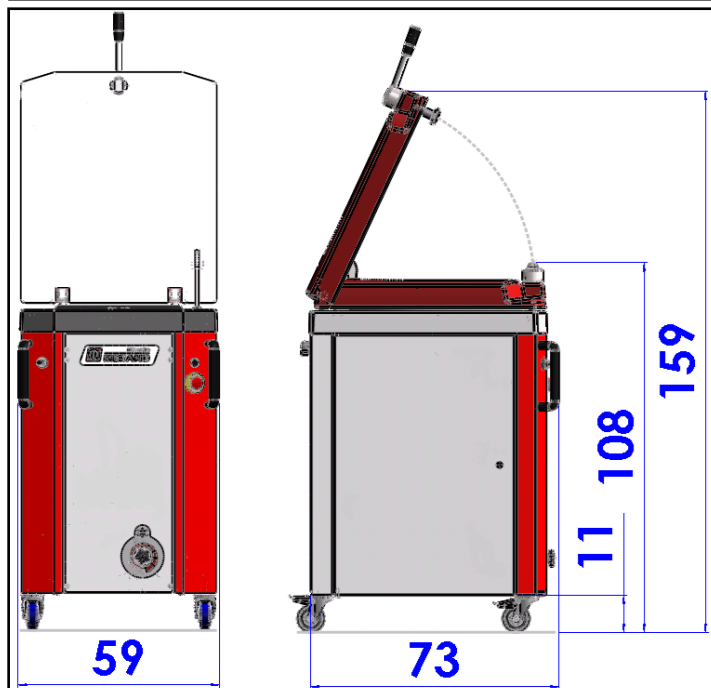

CAPACITY

Capacity of the tank in dough weight:

- 1 kg minimum.
- 20 kg maximum.

Information given for information purposes may vary according to the nature of the dough.

WEIGHT-PACKING

Net Weight: 180kg

Packed weight in cardboard box: 205kg

Packed weight in wooden crate: 235kg

Pallet and cardboard box dimensions:

Length : 100cm Width : 100cm Height : 136cm

Pallet and wooden crate dimensions:

Length : 100cm Width : 100cm Height : 136cm

ELECTRICAL FEATURES

Global electric power: 1,5 kW max at 50Hz

1,8 kW max at 60Hz

Voltage : 400 V / 230V tri.

Intensity : 4,5 A / 7,8 A.

Fréquency : 50 Hz / 60 Hz.

Protection : IP54.

SECURITY

The DIVA dividers are conform to:

- The machine directive 2006/42/CE.
- The labor law.



MERAND Mécapâte S.A. ■ Z.I de la Turbanière ■ BRECE ■ B.P 93329 ■ 35533 NOYAL / VILAINE CEDEX ■ FRANCE

+33 (0)2 99 04 15 30 ■ Fax +33 (0)2 99 04 15 31 ■ e-mail : salesdpt@merand.fr ■ site : www.merand.fr