

IRIS

IMPASTATRICE A SPIRALE

SPIRAL MIXER

SPIRAL-KNETER

PETRIN A SPIRALE

AMASADORA DE ESPIRAL



LOGIUDICE FORNI
technologies by tradition



- Nuove trasmissioni a cinghie trapezoidali con puleggia rinvio
- Struttura in acciaio di rilevante spessore montata su ruote
- Pannello comandi digitale o elettromeccanico
- Protezione vasca in ABS chiusa o con griglia in acciaio inossidabile.

[ENG]

- New double pulley belt transmission
- Heavy-thickness steel frame, wheels mounted
- Digital or electromechanic control panel
- Bowl safety guard in ABS, closed type or with stainless steel grid

[DEU]

- Neue Struktur, verdoppelte Bandsteuerung, mit Rollen
- Auf Rädern montierte, feste Stahlstruktur
- Digitale oder elektromechanische Steuerungspanel
- Ausgestaltete Schutzform für Schale entweder geschlossen mit ABS Decke, oder mit INOX Gitterrahmen

[FRA]

- Nouvelle transmission par courroies trapézoïdales avec poulie de renvoi
- Structure en acier de gros épaisseur montée sur roulettes
- Tableau de commandes digital ou électromécanique
- Protection de la cuve en ABS ou avec grille en acier Inox

[ESP]

- Nuevas transmisiones con doble poleas
- Estructura en acero de grueso espesor y montada sobre ruedas
- Mandos digitales o electromecánicos
- Protección artesa en ABS cerrada o con parrilla en acero inoxidable.

CARATTERISTICHE TECNICHE
TECHNICAL FEATURES
TECHNISCHE DATEN
CARACTERISTIQUES TECHNIQUES
CARACTERÍSTICAS TÉCNICAS

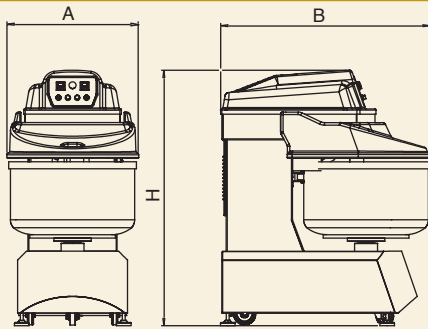

PANNELLO DIGITALE
DIGITAL CONTROL PANEL
DIGITALE BEDIENUNGSTAFEL
TABLEAU DIGITAL
PANEL DIGITAL



MODELLO MODEL MODELL MODELE MODELO	Farina Flour Mehl Farine Harina	Impasto Teig Pâte Dough Masa		Volume Vasca Bowl volume Kessel Volumen Volume Cuve Volumen artesa	Potenza Power Leistung Puissance Potencia	Peso Weight Gewicht Poids Peso	Dimensioni Dimensions Größe Dimensions Dimensiones		
	Kg	Kg		Lt	Kw	Kg	cm		
		Min.	Max.				A	B	H
IRIS 30	20	2	30	54	1,9	200	57	89	119
IRIS 40	27	4	40	63	1,9	200	57	89	119
IRIS 60	36	5	60	95	4,6	330	64	101	139
IRIS 80	50	6	80	127	4,6	410	75	119	145
IRIS 100	65	8	100	145	5,7	410	75	119	145
IRIS 130	80	12	130	193	6,9	580	85	140	150
IRIS 160	100	15	160	250	8,5	740	95	156	160
IRIS 200	125	17	200	275	8,5	740	95	156	160
IRIS 250	150	22	250	320	9,7	790	105	163	160
IRIS 300	180	27	300	420	12,5	840	113	173	166
IRIS 80 D	50	6	80	127	5,7	410	75	119	145
IRIS 100 D	65	8	100	145	6,4	410	75	119	145
IRIS 130 D	80	12	130	193	9,5	580	85	140	150
IRIS 160 D	100	15	160	250	12,5	740	95	156	160
IRIS 200 D	125	17	200	275	12,5	740	95	156	160
IRIS 250 D	150	22	250	320	17,2	790	105	163	160
IRIS 300 D	180	27	300	420	17,2	840	113	173	166

L'Azienda si riserva il diritto di apportare eventuali modifiche nell'ottica di un continuo miglioramento dei propri prodotti.
The Manufacture reserves the right to make any change to the product with the purpose of improving its quality.



LOGIUDICE FORNI s.r.l. Via Madonna Pellegrina, 29
37047 - San Bonifacio (VR) Italy
TEL. 0039 045 61 80126 - FAX. 0039 0442 490444
info@logiudiceforni.com - logiudiceforni@logiudiceforni.com - www.logiudiceforni.com

