



Model 625N-P

Semi-Automatic Dough Divider/Rounder

Key Features:

- Four machines in one
- Interchangeable dividing head assemblies
- Quick and easy tool-free changeover
- 36, 18, 9, and 6 part divisions
- Finished dough range 1—26 ounces
- Simply and quickly divide and round dough for breads, buns, pizza, tortillas
- Up to 5,000 pieces per hour
- Dividing head assemblies are dishwasher safe
- Standard unit includes 36 part dividing head and 2 dough paddles
- Option to customize with 18, 9 or 6-part



The information contained herein is correct to the best of our knowledge. The recommendations or suggestions are made without guarantee or representation as to results.

Above specifications subject to change without notice.



Manufactured in the U.S.A.



Model 625N-P

Semi-Automatic Dough Divider/Rounder Specifications:

Motor:

3 phase, 60Hz, 208V, 10 AMPS
Special electrics available

Finished portion sizes:

36 part: 1—2.75 oz (28—78 gr)

18 part: 2—7 oz (56—198 gr)

9 part: 7—18 oz (198—510 gr)

6 part: 19—26 oz (510—735 gr)

Minimum portion size (1 oz) requires 2 lbs 4 oz
dough ball and 36 part divider

Maximum portion size (18 oz) requires 10 lbs 2 oz
dough ball and 9 part divider

Finish:

White powder coat finish

Stainless steel cutting knives

Shipping Weight: 495 lbs (220.5 kg)

Net Weight: 449 lbs (202 kg)

Dimensions:

Footprint: 22" x 26 13/16"

Upright handle extends to 80 1/4"

Depressed handle extends depth of machine to 31"

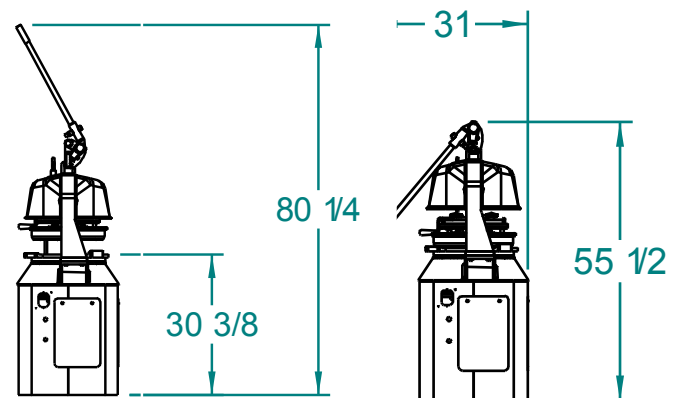
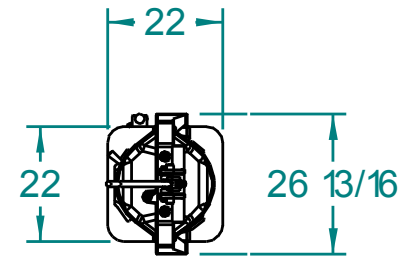

The information contained herein is correct to the best of our knowledge. The recommendations or suggestions are made without guarantee or representation as to results. Above specifications subject to change without notice.



Manufactured in the U.S.A.