



## Bun Divider

### Key Features:

- Constructed of cast iron and cast aluminum
  - Sanitary stainless steel pan included
  - Model 623-16 divides dough into 16 pieces
    - 2 lbs = 2 oz. (57g) finished pieces up to 8 lbs = 8 oz. (227g) finished pieces\*
  - Model 623-36 divides dough into 36 pieces
    - 2.25 lbs = 1oz. (28g) finished pieces up to 9 lbs = 4 oz. (113g) finished pieces\*
- \*divided product final size dependent on starting dough weight/number of divisions*
- Optional stand available



623 with Optional Stand

### Specifications:

#### Shipping Weight:

150 lbs. (68kg)

#### Net Weight:

135 lbs. (61kg)

#### Height:

41" (1,041mm)

#### Width:

17 3/4" (451mm)

#### Length:

19 3/4" (502mm)

#### Optional:

floor stand with casters

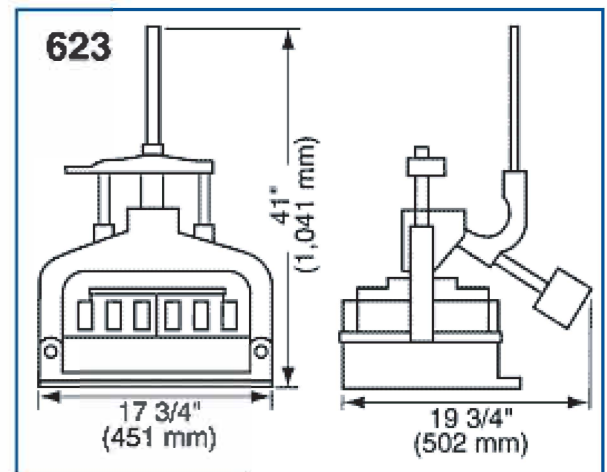

The information contained herein is correct to the best of our knowledge. The recommendations or suggestions are made without guarantee or representation as to results.

Above specifications subject to change without notice.



**Manufactured in the U.S.A.**