



Dough Press

Key Features:

- Manual operation; press up to 40 lbs. (14kg) of dough
- Hydraulic operation helps reduce noise and vibration
- Easy access for maintenance
- Latches with a double safety lock
- The lid and sides of the hopper are made of heavy cast aluminum. The pressing plate is made of anti-adherent, food-grade plastic which helps prevent sticking and oiling of dough
- Easy to move, with four heavy duty castors
- Available in stainless steel or white powder coated covers



The information contained herein is correct to the best of our knowledge. The recommendations or suggestions are made without guarantee or representation as to results.

Above specifications subject to change without notice.



Manufactured in the U.S.A.



Dough Press

SPECIFICATIONS:

Electrics:

- 2 H.P., 3 phase, 60Hz, 230 VAC, 6.2 AMPS
 - 2 H.P., 3 phase, 60Hz, 208 VAC, 6.5 AMPS
 - 2 H.P., 3 phase, 60Hz, 460 VAC, 3.1 AMPS
 - 2 H.P., Single Phase, 60Hz, 230 VAC, 10.0 AMPS
- Special electrics also available

Capacity:

10 1/2 lbs. (4.8kg); to approximately 40 lbs. (14kg)

Shipping Weight:

500 lbs. (227kg)

Net Weight:

485 lbs. (207kg)

Height:

42 1/8" (107cm) with open lid 65" (166cm)

Width:

21 3/4" (55cm) Depth: 30" (77cm) with open lid

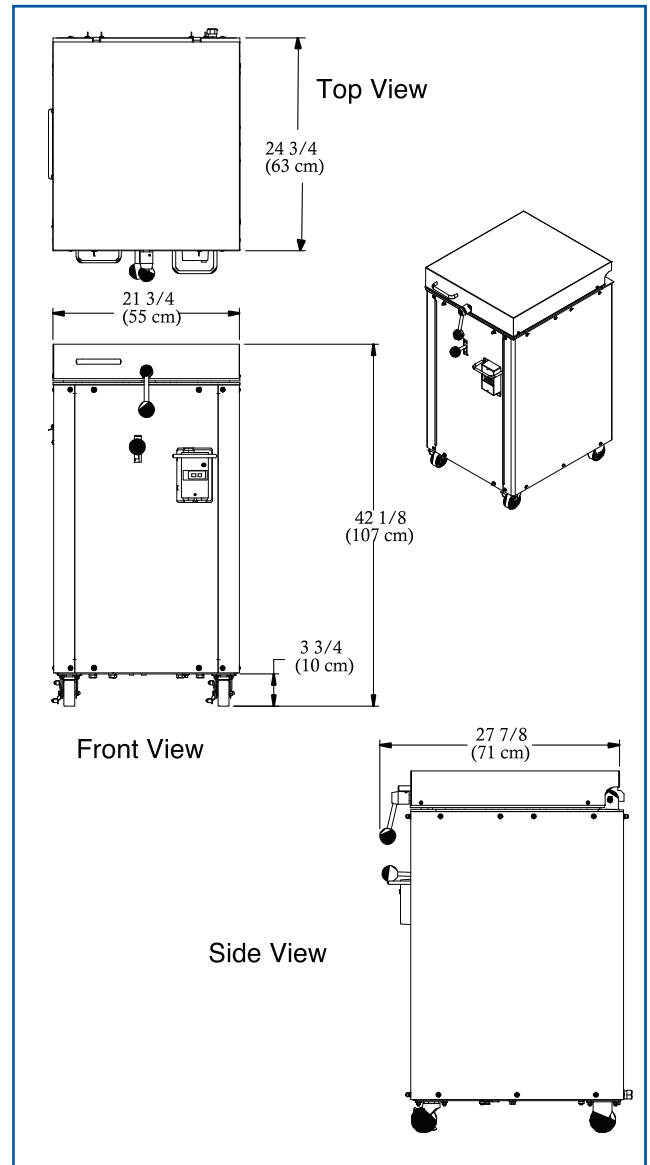

The information contained herein is correct to the best of our knowledge. The recommendations or suggestions are made without guarantee or representation as to results.

Above specifications subject to change without notice.

Manufactured in the U.S.A.